

# Eclipse Valve Trains

1/2" thru 1-1/2" NPT

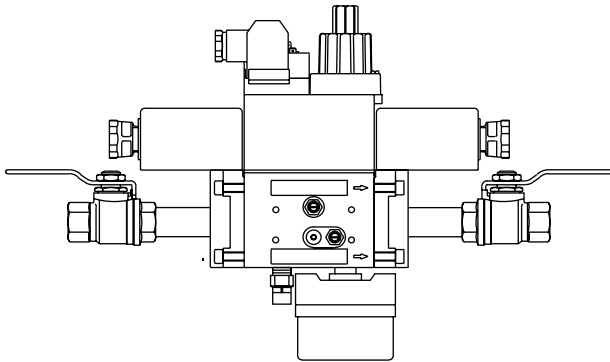

## Agency Approvals:



UL Listed



CGA certified



FM Approved

APPROVED

## Features

The standard Eclipse valve train, size 1/2" through 1-1/2", uses Dung's DMV-DLE shutoff valve and associated components. The valve trains, which meet either NFPA 86\* or IRI requirements, are NEMA 1 rated and are designed for 110-120V, 50-60 Hz operation.

The NFPA 86 version\* of the DMV valve train is equipped with visual and electronic position indication and includes pressure taps for valve seat leak testing. The IRI version adds the VPS 504 while removing electronic position indication. Other standard components include a 2 - 20"w.c. low pressure switch and 12 - 60"w.c. high pressure switch.

\* Must add a valve proving system to meet this standard.

## Optional components

- Pressure regulator with a 12 - 28"w.c. spring
- Pressure gauges

## Pressure Rating

- 2 psi for valve trains with standard high pressure switch
- 7 psi with the addition of an FRI regulator

## Temperature Rating

- -40°F to 140°F for standard valve trains
- 5°F to 140°F when using the FRI regulator

Pipe Size NPT	Standard Valve Trains			Capacity cfh Natural Gas	Pressure Drop @ 1 psi Inlet	FRI Regulator Item Code	Additional Length with FRI inches (mm)
	NFPA 86 Item Code	IRI Item Code	Length inches (mm)				
1/2"	100278	100290	13.98 (355)	300	0.8" w.c. (1.99 mbar)	21886	3.63 (92.20)
3/4"	100279	100291	14.88 (378)	560	1.7" w.c. (4.23 mbar)	20749	3.63 (92.20)
1"	100280	100292	18.70 (475)	1,100	5.7" w.c. (14.19 mbar)	20749	3.63 (92.20)
1-1/2"	100281	100293	23.50 (597)	3,200	5.4" w.c. (13.44 mbar)	20751	4.88 (123.95)

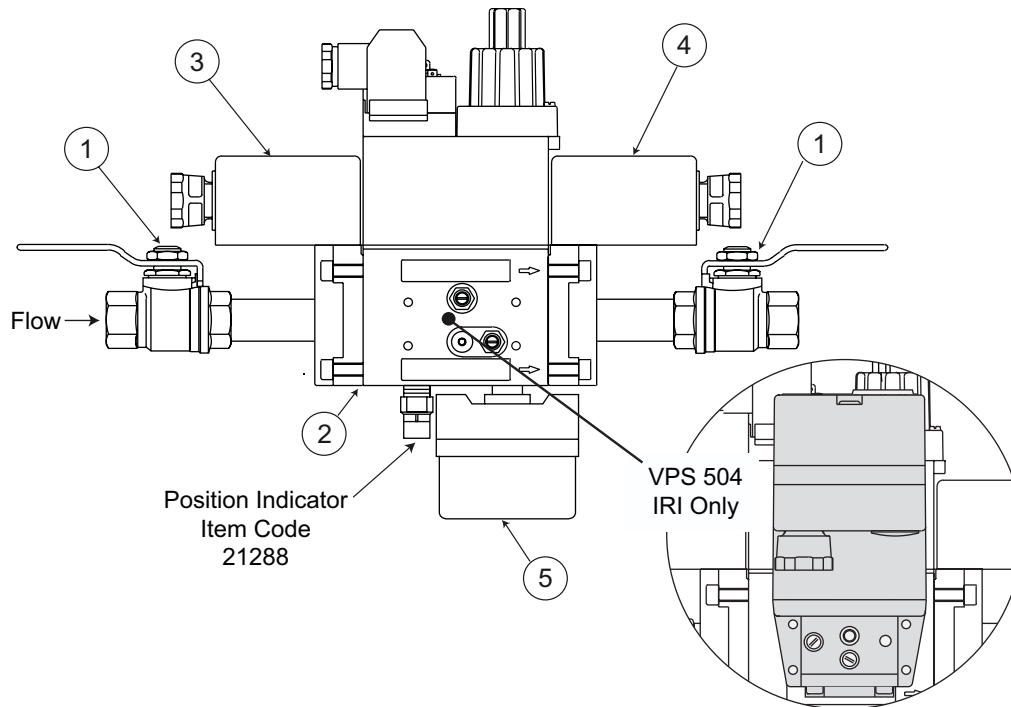

Pipe Size NPT	Item 1	Item 2	Item 3	Item 4	Item 5	Optional
	Manual Shutoff Valve	Automatic Shutoff Valve	Low Pressure Switch	High Pressure Switch	Position Indication Switch	FRI Regulator
1/2"	Ball Valve 10334	DMV-DLE 701/602 20743 DMV-DLE 701/622 10007552	GAO-A2-4-5 2 - 20" w.c. 21196	GAO-A2-4-6 12 - 60" w.c. 21196-1	Not Required	FRI 705/6 21886
3/4"	Ball Valve 10334				CPI 400 20741	FRI 707/6 20749
1"	Ball Valve 10348					FRI 712/6 20751
1-1/2"	Ball Valve 10357	DMV-DLE 702/602 20744 DMV-DLE 702/622 10006097				

## Accessories

### FRI Pressure Regulators with 4 - 12 " w.c. Standard Spring

Item	Model
21886	FRI 705/6
20749	FRI 707/6
20751	FRI 712/6

### Optional FRI Pressure Regulator Springs

Item	Range	For use with Regulator Model:
20749-2	10 - 22" w.c.	FRI 705/6, 707/6
20749-2	12 - 28" w.c.	FRI 705/6, 707/6
20750-2	10 - 22" w.c.	FRI 712/6
20750-3	12 - 28" w.c.	FRI 712/6

### Pressure Gauges 2-1/2" Dial

Item	Range
14658	0 - 35" w.c.
13817	0 - 60" w.c.

### Parts Required to Connect Pressure Gauge

Qty	Item	Description
1	21836	Mounting block, 1/4" NPT
1	18702	Pipe nipple, 1/4" NPT x 4"
1	10328	Valve, ball, 1/4" NPT



**Offered By:**

Power Equipment Company  
2011 Williamsburg Road  
Richmond, Virginia 23231  
Phone (804) 236-3800  
Fax (804) 236-3882

---

[www.peconet.com](http://www.peconet.com)